

CPA Type A Flow Conditioner – Raised Face – FOEL/FOE

In typical raised face configurations, installation of the CPA (50E, 55E, 65E) flow conditioner involves placing the plate between two ANSI Raised Face (RF) flanges.

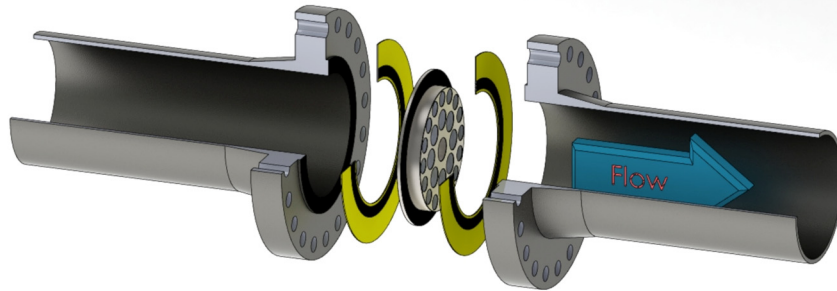
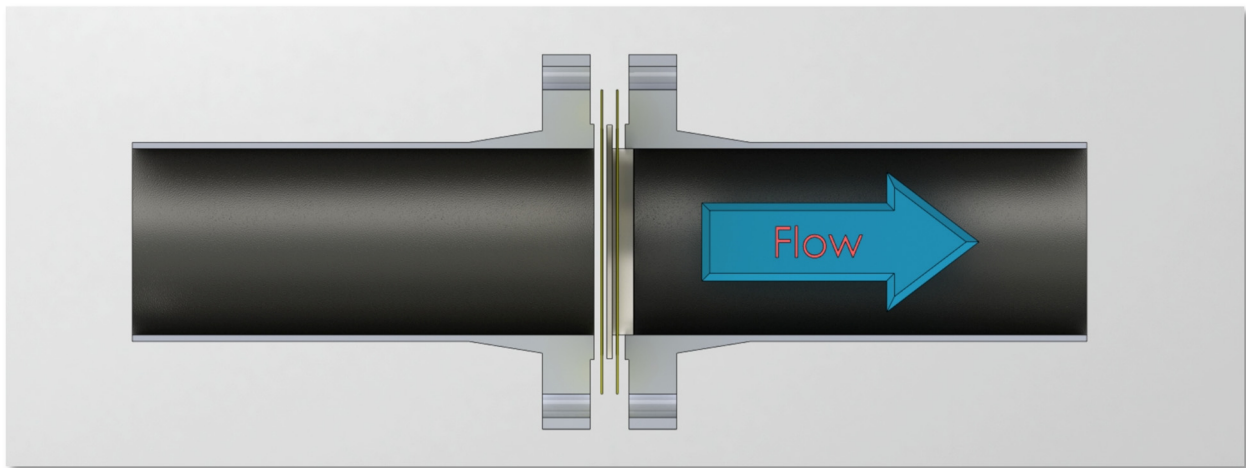

Plate Installation

The flush face of the CPA RF flow conditioner should always be positioned against the upstream flange of the meter tube. This ensures that the flow conditioner is centered relative to the flow meter and allows the upstream meter run spool to be slid out of the pipe without the pipe flanges being spread.



While there is a flow direction arrow on the CPA RF flange that helps indicate this orientation, the flow conditioner geometry is bi-directional and can be installed backwards without causing a change in flow meter performance.

CPA recommends use of spiral wound gaskets that have an OD centering ring and an ID ring to contain the gasket windings. This helps reduce the possibility of the gasket sliding and blocking the flow conditioner holes during installation or unwinding during operation.

Canada Pipeline Accessories offers gaskets for use with flow conditioners in any ANSI application. Please contact CPA for more information.

Plate Orientation

For installation convenience, the CPA flow conditioner has a top dead center marker known as the FloAlign notch on the outer circumference of the flange. This engraved notch is aligned with the 90-degree axis of the flow conditioner and is provided to help with flow conditioner orientation when using Ultrasonic flow meters. CPA flow conditioner orientation is not applicable to measurement performance when using other flow meter types.

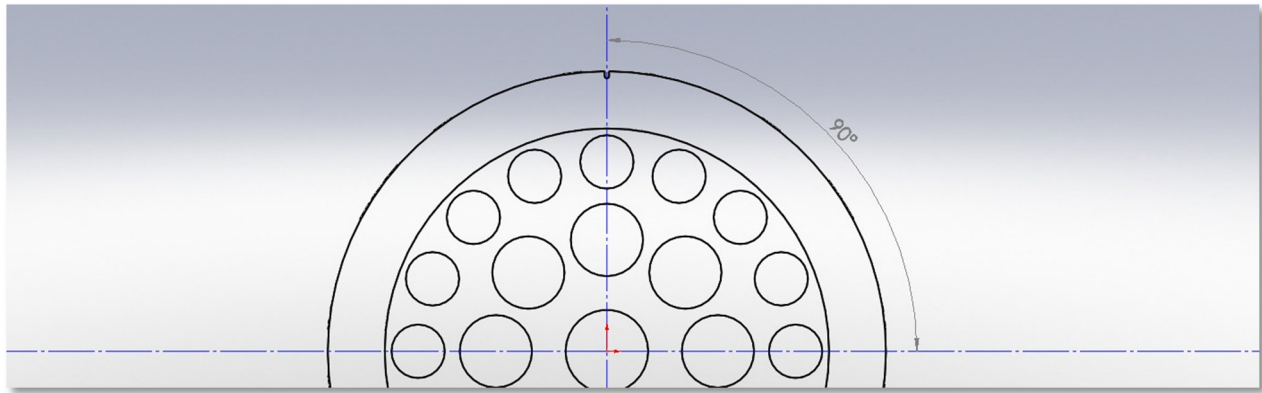

Plate Maintenance and Cleaning

The CPA flow conditioner is a low maintenance device and does not require scheduled servicing. It should be inspected on a regular basis for debris collection and hole blockages. These obstructions can result in a severe reduction in flow conditioner performance that can increase flow meter error.

Over time, a buildup of dirt and contamination will require cleaning of the flow conditioner. This can be done with a soft rag and any available solvent. **CLEANING MUST NOT BE PERFORMED WITH ANY TYPE OF ABRASIVE MATERIAL OR HONING DEVICE.** Abrasive cleaning can inadvertently change the dimensions of the plate and cause it to fall out of CPA's specifications. This will reduce the performance of the flow conditioner as well as possibly resulting in undesired acoustic and pressure drop behavior.

Physical damage to the flow conditioner due to debris impacts will require replacement of the flow conditioner to maintain the CPA specified performance.

Sizes and Availability

- Available in a range of sizes, from NPS 1/2" to NPS 48".
- Wide range of material options: Nickel Surfaced Carbon Steel, 304 Stainless Steel, 316 Stainless Steel, Inconel, Monel, Duplex, Hastalloy.
- Compatible with ANSI ratings of 150# to 2500#.
- Stocked in sizes 1" thru 20" in common schedules for immediate delivery.
- Custom sizes are available; please contact CPA for more information!